

UNIT, DIRECT SUPPORT, AND GENERAL SUPPORT MAINTENANCE
REPAIR PARTS AND SPECIAL TOOLS LIST
TRUCK, 5-TON, 6X6, M809 SERIES TRUCKS (DIESEL)

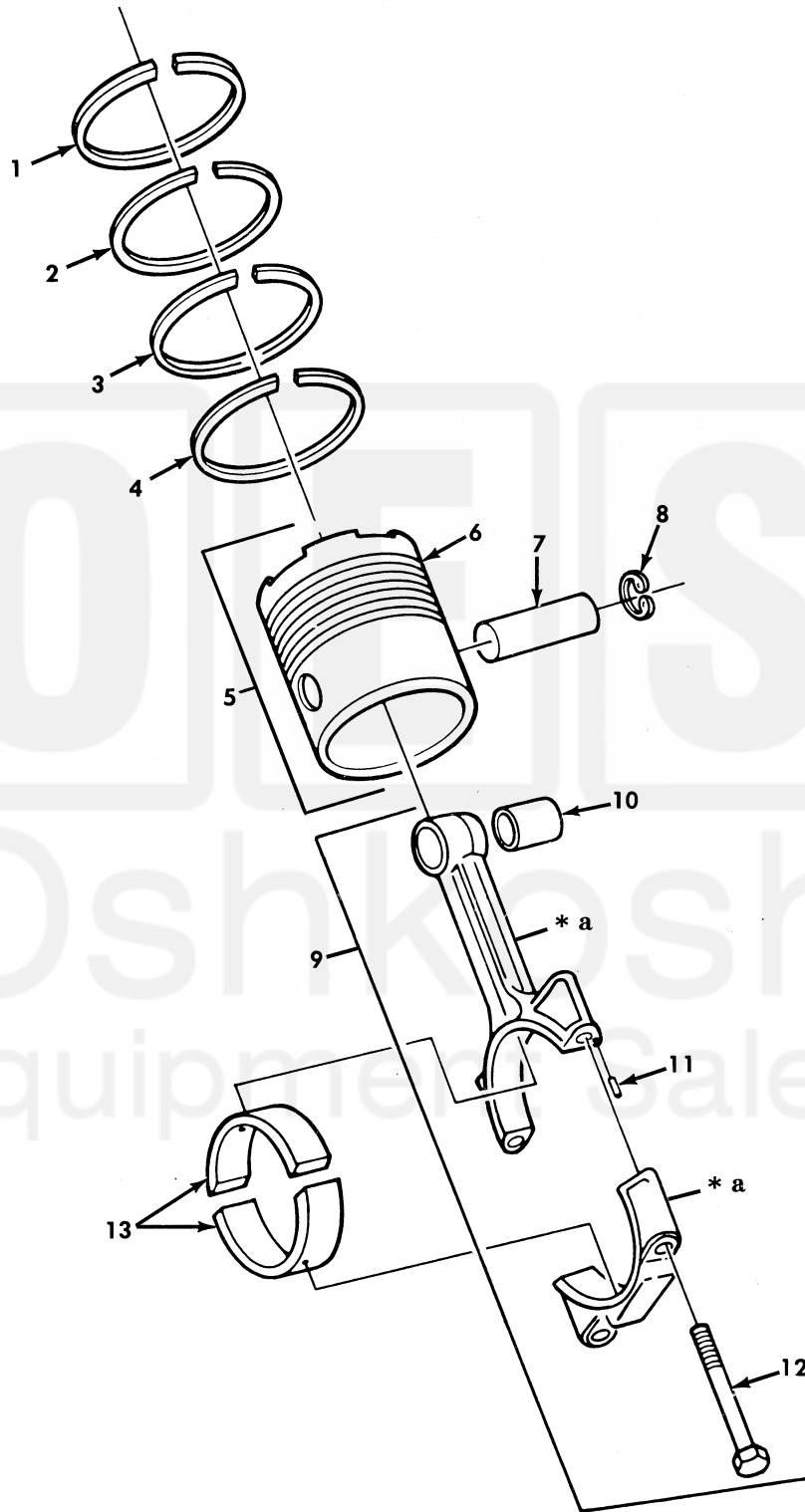

* a PART OF ITEM 9

Figure 10. Piston and Rod Assembly.

(1) ITEM NO	(2) SMR CODE	(3) NSN	(4) CAGEC	(5) PART NUMBER	(6) DESCRIPTION AND USABLE ON CODE (UOC)	(7) QTY
GROUP 0104 PISTONS,CONNECTING RODS						
FIG. 10 PISTON AND ROD ASSEMBLY						
1	KFHZZ		15434	3012331	RING,PISTON PART OF KIT P/N 3801056	6
2	KFHZZ		15434	3012332	RING,PISTON PART OF KIT P/N 3801056	6
3	KFHZZ		15434	214730	RING,PISTON PART OF KIT P/N 3801056	6
4	KFHZZ		15434	218732	RING,PISTON PART OF KIT P/N 3801056	6
5	PAHZZ	2815-00-008-1741	01212	2622PN	PISTON,INTERNAL COM PART OF KIT P/N 3801795.....	6
6	XAHZZ		15434	3025516	.PISTON,INTERNAL COM.....	1
7	XAHZZ		15434	191970 XA	.PIN,PISTON.....	1
8	PAHZZ	5325-00-804-2784	96906	MS16625-1200	.RING,RETAINING.....	2
9	PAHZZ	2815-01-086-4508	15434	3013930	CONNECTING ROD,PIST.....	6
10	PAHZZ	5365-00-132-0273	15434	187420	.BUSHING,PISTON PIN.....	1
11	PAHZZ	2815-01-124-0232	15434	70550	.PIN,PISTON.....	2
12	PAHZZ	5306-01-079-7027	15434	219153	.BOLT,MACHINE.....	2
13	PAHZZ	3120-01-087-3004	15434	214950	BEARING STANDARD.....	12
13	PAHZZ	3120-01-155-4442	15434	214951	BEARING HALF,SLEEVE .010, UNDERSIZE	12
13	PAHZZ	3120-01-157-3316	15434	214952	BEARING,SLEEVE .020, UNDERSIZE.....	12
13	PAHZZ	3120-01-155-8707	15434	214953	BEARING HALF,SLEEVE .030, UNDERSIZE	12
13	PAHZZ	3120-00-300-0884	15434	203660	BEARING HALF,SLEEVE STD,USE BEFORE SERIAL NUMBER 11246663.....	12
13	PAHZZ	3120-01-139-6525	15434	203661	BEARING SET,SLEEVE .010,USE BEFORE SERIAL NUMBER 11246663.....	12
13	PAHZZ	3120-00-429-3967	15434	203662	BEARING,SET .020,USE BEFORE SERIAL NUMBER 11246663.....	12
13	PAHZZ	3120-01-284-0770	15434	203663	BEARING HALE,SLEEVE .030,USE BEFORE SERIAL NUMBER 11246663.....	12

END OF FIGURE

